

## A brighter solution to get hot water.

**2 of 3**  
SHOWERS  
FOR FREE!

SoletAer MDX Solar Heat Pump, designed for energy efficient production of domestic hot water.

SoletAer MDX combines solar technology and heat pump technology in order to make tap water heating more energy efficient.

It is mounted on the outer wall of a house and is connected to SoletAer 260 stainless steel water heater or an existing electric water heater.

SoletAer MDX have a built-in controller that chooses the best operating mode and always prioritizes solar operation.

SoletAer MDX uses solar energy to heat the water which also benefits the environment.

- With SoletAer, you pay only 1 of 3 showers in one year
- Sunny days, at spring, summer and autumn, SoletAer produces domestic hot water for free
- Easy installation to existing electric water heater
- Excellent complement to other heating systems

SoletAer

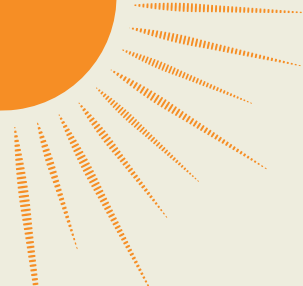

### SoletAer MDX

solar heat pump

SoletAer compared to traditional air-to-water heat pumps run up to 20 times longer between defrosting cycles.

SoletAer is thereby saving energy spent on melting ice. This is possible due to the following patented innovations:

- » Evaporator coil with large front area reduces the need of defrosting significantly compared to traditional air-to-water heat pumps.
- » The solar panel has an evaporating effect which further reduces the need for defrosting.

Solar panel with dual refrigerant circuits. Solar heating creates a thermosiphon, natural circulation occurs as a result of absorbed solar energy. The air-to-water heat pump operates only when the solar contribution is insufficient during winter and night.

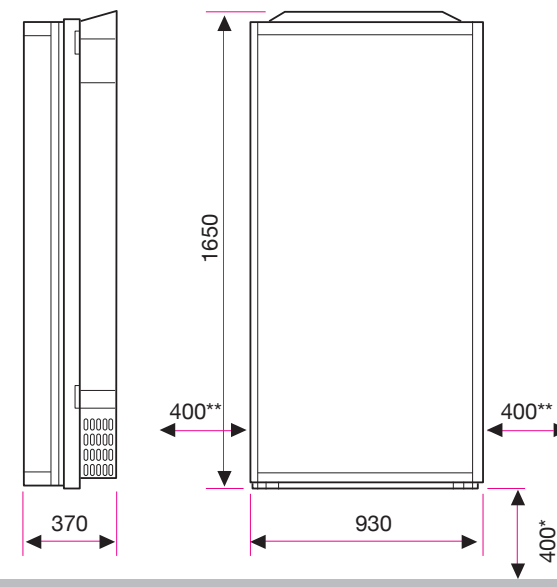
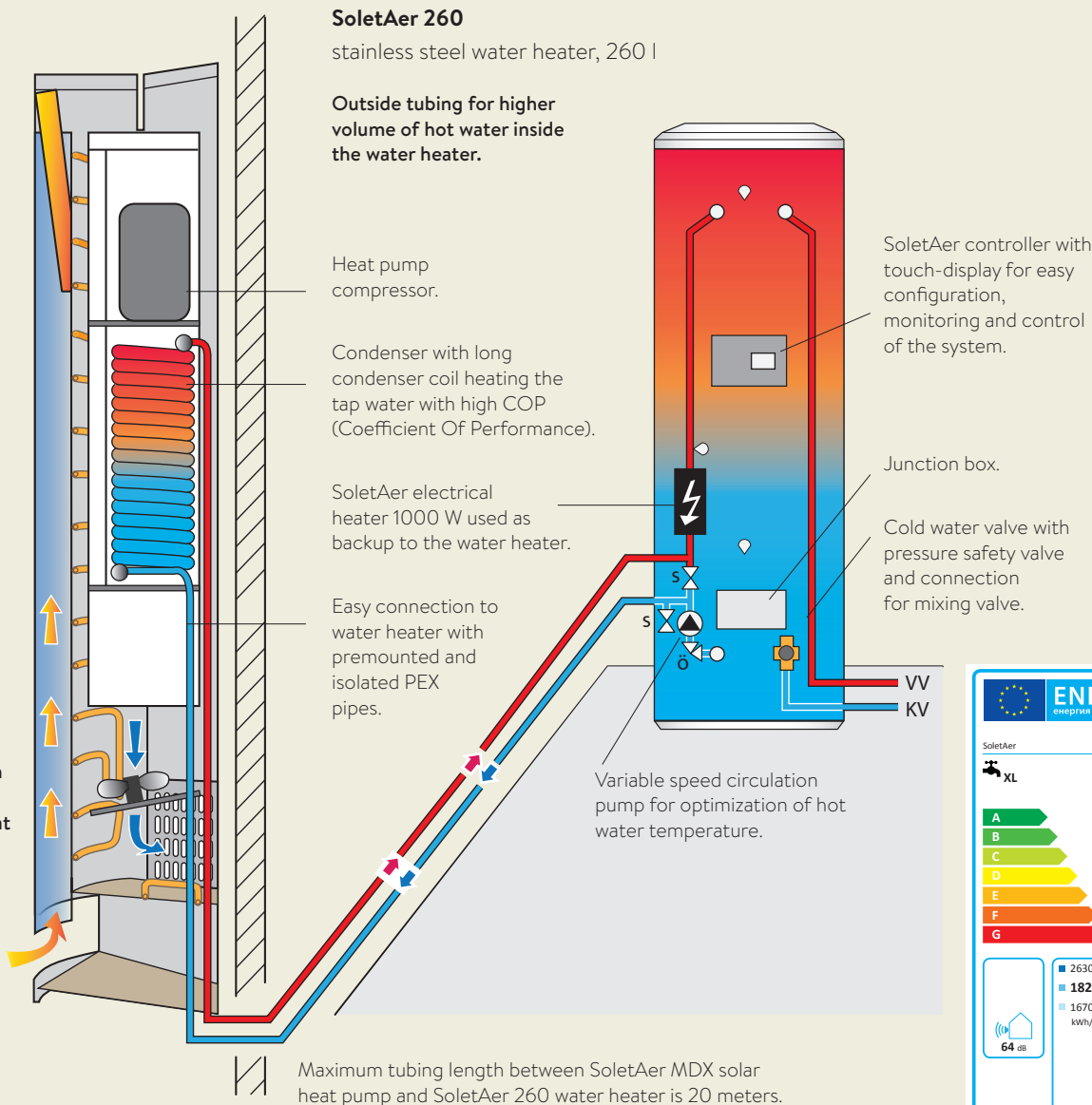

\* Minimum measurements for air inlet, (mm).

\*\* Minimum space left and right, (mm).

### TECHNICAL DATA

Height: 1650 mm  
 Width: 930 mm  
 Depth: 370 mm  
 Weight: 120 kg  
 Power: 230V 10A

### HEAT OUTPUT

Heat pump: 1510 W at +7°/45°C  
 Power input: 560 W (incl. fan, waterpump)  
 Solar panel: 500 W  
 Electric heater: 1000 W single phase 230V  
 Circulation pump: 4 W, 12V direct current